



Reg. No.

AUHIPPO.COM\*



**Question Paper Code : 20458**

B.E./B.Tech. DEGREE EXAMINATION, NOVEMBER/DECEMBER 2018.

Fifth Semester

Electrical and Electronics Engineering

EE 6501 — POWER SYSTEM ANALYSIS

(Regulations 2013)

(Also Common to PTEE 6501 — Power System Analysis — For B.E. (Part – Time) —  
Fifth Semester — Electrical and Electronics Engineering – Regulations – 2014)

Time : Three hours

Maximum : 100 marks

Answer ALL questions.

PART A — (10 × 2 = 20 marks)

1. What is the need for base values?
2. What are the approximations made in impedance diagram?
3. What is the need for slack bus?
4. When the generator bus is treated as load bus in NR load flow study? What will be the reactive power and bus voltage when the generator bus is treated as load bus?
5. What is the need for short circuit studies or fault analysis?
6. What is the significance of subtransient reactance and transient reactance in short circuit studies?
7. Define negative sequence and zero sequence components.
8. Define the operator 'a' and express the value of 'a' and 'a<sup>2</sup>' in both polar and rectangular form.
9. What are coherent machines?
10. How to improve the transient stability limit of the power system.

**AUHIPPO.COM**

PART B — (5 × 13 = 65 marks)

11. (a) 300 MVA, 20 kV three-phase generator has a subtransient reactance of 20%. The generator supplies a number of synchronous motors over 64-km transmission line having transformers at both ends, as shown in Figure.1 All motors are rated as 13.2 kV and represented by just two equivalent motors. Rated inputs to the motors are 200 MVA and 100 MVA for M1 and M2, respectively. For both motors  $X'' = 20\%$ . The three phase transformer T1 is rated 350 MVA, 230/20 kV with leakage reactance of 10%. Transformer T2 is composed of three single-phase transformers each rated 127/13.2 kV, 100 MVA with leakage reactance of 10%. Series reactance of the transmission line is  $0.5\Omega/\text{km}$ . Draw the impedance diagram, with all impedances marked in per-unit. Select the generator rating as base in the generator circuit. (13)



Figure. 1  
Or

- (b) Draw the impedance diagram of the power system shown in below Figure. 2.

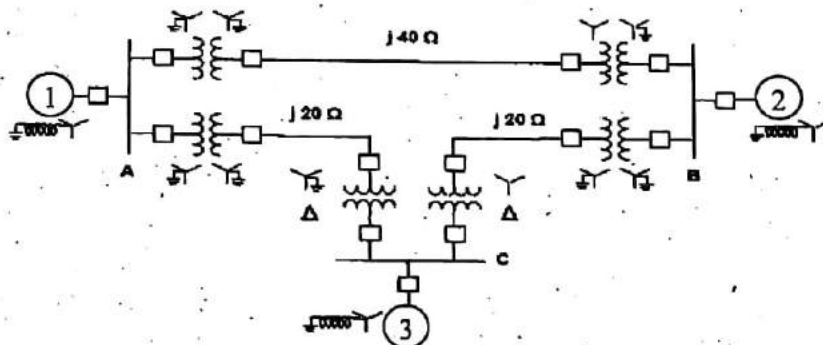

Figure. 2

Mark impedances in per unit. Neglect resistance and use a base of 50 MVA, 138 kV in the 40- $\Omega$  line. The ratings of the generator, motors and transformers are:

Generator 1: 20 MVA, 18 kV,  $X'' = 20\%$

Generator 2: 20 MVA, 18 kV,  $X'' = 20\%$

Synchronous motor 3: 30 MVA, 13.8 kV,  $X'' = 20\%$

Three phase Y-Y transformers: 20 MVA, 138Y/20Y kV,  $X = 10\%$

Three phase Y- $\Delta$  transformers: 15 MVA, 138Y/13.8  $\Delta$  kV,  $X = 10\%$ . (13)

12. (a) With a neat flow chart explain the computational procedure for load flow solution using Gauss-Seidal method when the system contains all types of busses.

Or

- (b) (i) Develop a power flow equation at any bus in a power system. (6)  
(ii) Evaluate the Jacobian elements for NR load flow. (7)

13. (a) Construct Z Bus for the given network shown in Figure. 3 (13)

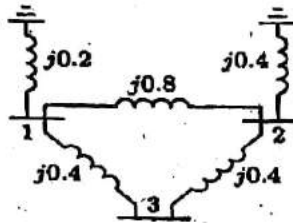

Figure. 3  
Or

- (b) A 25 MVA, 11 kV generator with  $X_d'' = 20\%$  is connected through a transformer, line and a transformer to a bus that supplies three identical motors as shown in Figure. 4. Each motor has  $X_d'' = 25\%$  and  $X_d' = 30\%$  on a base of 5 MVA, 6.6 kV. The three-phase rating of the step-up transformer is 25 MVA, 11/66 kV with a leakage reactance of 10% and that of the step-down transformer is 25 MVA, 66/6.6 kV with a leakage reactance of 10%. The bus voltage at the motors is 6.6 kV when a three-phase fault occurs at the point F.

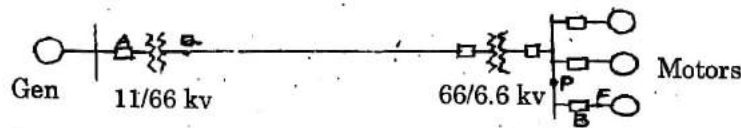

Figure. 4

For the specified fault, calculate

- (i) the subtransient current in the fault,
- (ii) the subtransient current in the breaker
- (iii) the momentary current in breaker B, and
- (iv) the current to be interrupted by breaker B in five cycle (13)



14. (a) Derive an expression for fault current as line-to-line fault on an unloaded generator. (13)

Or

- (b) A single line to ground fault (on phase a) occurs on the bus I of the system of Figure shown Figure. 5

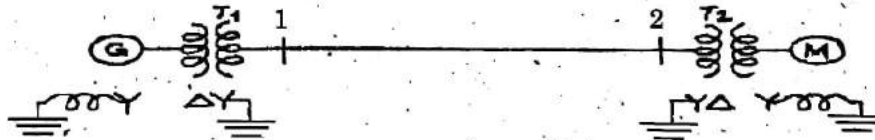

Figure. 5

Using bus impedance ( $Z_{bus}$ ) method Find

- (i) Current in the fault.
- (ii) SC current on the transmission line in all the three phases.
- (iii) SC current in phase 'a' of the generator.
- (iv) Voltage of the healthy phases of the bus1. (13)

Given: Rating of each machine 1200 kVA, 600 v with  $X' = X_2 = 10\%$   
 $X_0 = 5\%$ . Each three-phase transformer is rated 1200 kVA,  
 600/3300v (Delta/Star) with leakage reactance of 5%. The reactances of  
 the transmission line are  $X_1 = X_2 = 20\%$  and  $X_0 = 40\%$  on a base of  
 1200 kVA, 3300 V. The reactances of the neutral grounding reactors are  
 5% on the kVA and voltage base of the machine. (13)

15. (a) Write the swing equation describing the rotor dynamics of a synchronous machine connected to infinite bus through a double circuit transmission line. (13)

Or

- (b) The per unit system reactances that are converted in a common base, are shown in this Figure. 6. Let us assume that the infinite bus voltage is  $1\angle 0^\circ$ . The generator is delivering 1.0 per unit real power at a lagging power factor of 0.9839 to the infinite bus. While the generator is operating in steady state, a three-phase bolted short circuit occurs in the transmission line connecting buses 2 and 4 — very near to bus 4. The fault is cleared by opening the circuit breakers at the two ends of this line, find the critical clearing time for various values of  $H$ . (13)

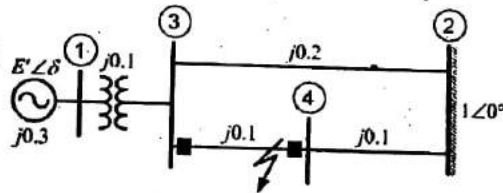

Figure. 6

PART C — (1 × 15 = 15 marks)

16. (a) Figure. 7 shows a part of a power system, where the rest of the system at two points of coupling have been represented by their Thevenin's equivalent circuit (or by a voltage source of 1 pu together its fault level which corresponds to the per unit value of the effective Thevenin's impedance). (15)

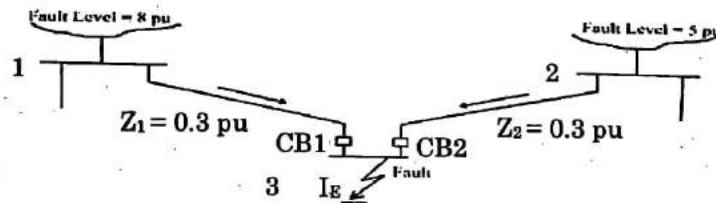

Figure. 7

With CB1 and CB2 open, short circuit capacities are

SCC at bus 1 = 8 pu. gives  $Z_{g1} = 1/8 = 0.125$  pu

SCC at bus 2 = 5 pu. gives  $Z_{g2} = 1/5 = 0.20$  pu

Each of the lines are given to have a per unit impedance of 0.3 pu.

$Z_1 = Z_2 = 0.3$  p.u.

Determine the fault current at bus 3.

Or

- (b) Discuss in detail the importance of Power system stability study. Also discuss the solution of swing equation by Euler method and RK method.