

PART C — (1 × 15 = 15 marks)

16. (a) Design a lag compensator for the system given by  $G(s) = \frac{K}{s(s+2)}$  to meet the following design specifications
- Static velocity error constant  $K_v = 10 \text{ sec}^{-1}$  and
  - Phase margin  $\Phi_m \geq 60^\circ$ .

Or

- (b) A unity feedback control system has an open loop transfer function  $G(s) = \frac{K}{s(s+1)(s+2)}$ . Make a rough sketch of the root locus plot of the system, explicitly identifying the centroid, the asymptotes, the departure angles from the complex poles of  $G(s)$  and the  $j\omega$ -axis crossover point. By trial-and-error application of the angle criterion, locate a point on the locus that gives dominant closed loop poles with  $\zeta = 0.5$ . Evaluate the value of  $K$  at this point.

Reg. No. : 

Question Paper Code : 80198



B.E/B Tech. DEGREE EXAMINATIONS, APRIL/MAY 2019.

Fourth Semester

Instrumentation and Control Engineering

IC 8451 — CONTROL SYSTEMS

(Common to Electrical and Electronics Engineering/Electronics and Instrumentation Engineering)

(Regulation 2017)

Time : Three hours

Maximum : 100 marks

Answer ALL questions.

PART A — (10 × 2 = 20 marks)

- Tabulate the parameters of the translational and rotational mechanical systems.
- For the mechanical system shown in figure.1, draw the corresponding Force-Voltage analogy circuit.

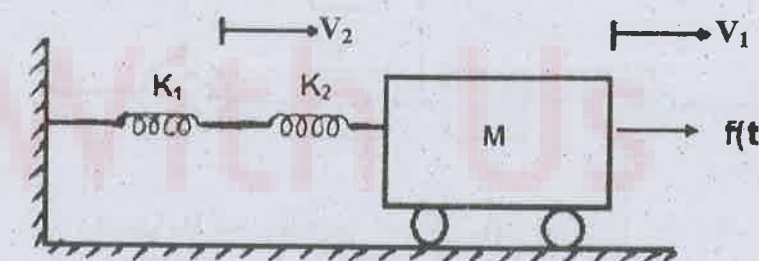

Figure - 1

- Mention the effects of Proportional Integral (PI) controller.
- For servomechanisms with open loop transfer function given by  $G(S) = \frac{1}{s^2 + 2s + 3}$ , Determine the position error and steady state error for a unit step input.
- The damping ratio and natural frequency of oscillations of a second order system is 0.3 and 3 rad/sec respectively. Calculate resonant frequency and resonant peak.

6. If the bode plot crosses 180° line, either at very low frequencies or very high frequencies in the selected frequency range, what is the inference regarding the relationship between open loop gain and stability?
7. What is compensation? Why are compensators required in feedback control systems?
8. For what range of K the following system shown in figure. 2 is asymptotically stable?

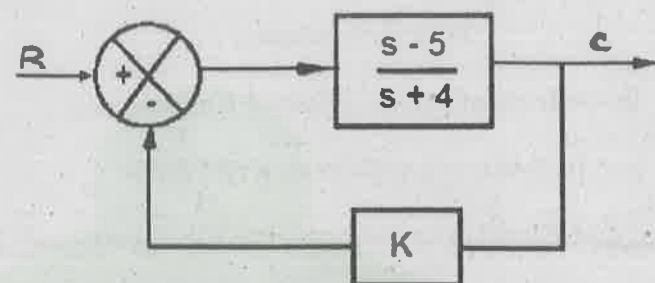

Figure - 2

9. Enumerate the advantages of state space analysis.
10. State the mechanism in control engineering which implies an ability to measure the state by taking measurements at output?

PART B — (5 × 13 = 65 marks)

11. (a) Draw a signal flow graph and obtain the closed loop transfer function of a system whose block diagram is given in Figure. 3

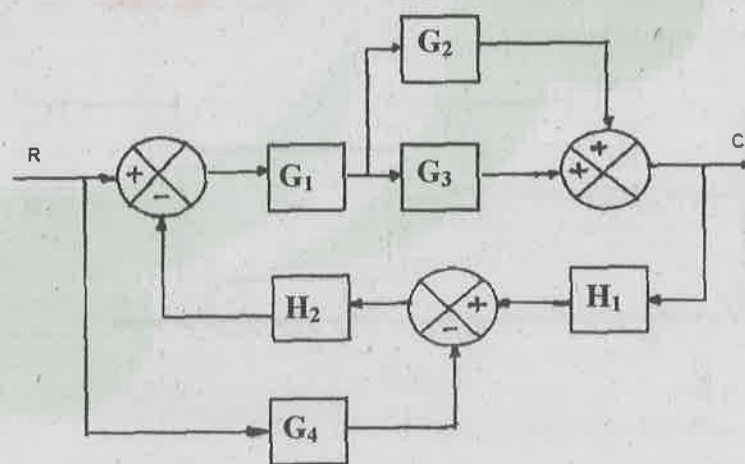

Figure - 3

Or

- (b) Define transfer function and derive the transfer function at field controlled DC servomotor.

12. (a) A unity feedback system is characterized by the open loop transfer function.

$$G(s) = \frac{1}{s(0.5s+1)(0.2s+1)}$$

- (i) Write the closed loop transfer function  $\frac{C(s)}{R(s)}$
- (ii) Find damping factor, natural frequency of the system
- (iii) Determine rise time, peak time and peak overshoot of the system
- (iv) Calculate steady state Error due to unit-step input.

Or

- (b) Derive the expression for rise time and peak time of a second order under damped system due to unit step input.

13. (a) Sketch the Bode plot for the transfer function of a system represented by  $G(S) = \frac{100}{s(s+1)(s+2)}$  and determine (i) Gain Margin (ii) Phase Margin and closed loop stability.

Or

- (b) Sketch the Polar plot for the following open loop transfer function and determine the gain margin and phase margin  $G(s) = \frac{1}{(1+s)(1+2s)}$ .

14. (a) (i) Assume any four different pole locations for a system sketch the response and comment on stability of each case. (7)
- (ii) For the given characteristic equation examine the stability of the system using Routh's criterion  $s^5 + 4s^4 + 8s^3 + 8s^2 + 7s + 4 = 0$ . (6)

Or

- (b) From the first principles explain how do you obtain the stability of a linear system using Nyquist criterion?

15. (a) Consider the following RLC series circuit shown in figure. 4 and obtain its state model.

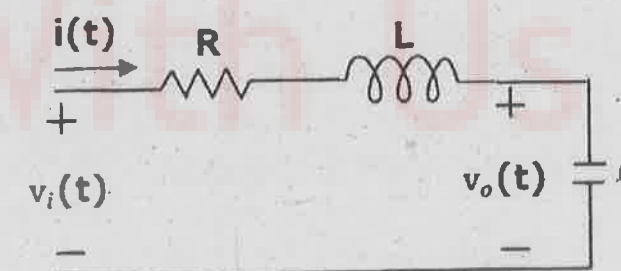

Figure - 4

Or

- (b) Consider the following plant of the state-space representation:

$$A = \begin{bmatrix} 0 & 1 \\ -2 & -3 \end{bmatrix} \quad B = \begin{bmatrix} -2 \\ 2 \end{bmatrix} \quad C = [-2 \ 0]$$

Examine the Controllability and Observability of a state-space formed by the system.