

Reg. No. :

--	--	--	--	--	--	--	--	--	--	--	--	--	--	--	--	--	--	--	--

**Question Paper Code : 80656**

B.E./B.Tech. DEGREE EXAMINATION, NOVEMBER/DECEMBER 2016.

Fourth Semester

Mechanical Engineering

ME 6401 — KINEMATICS OF MACHINERY

(Common to Third Semester Mechanical Engineering (Sandwich),  
Mechatronics Engineering)

(Regulations 2013)

Time : Three hours

Maximum : 100 marks

Answer ALL questions.

PART A — (10 × 2 = 20 marks)

1. Differentiate rigid and flexible links.
2. Define Transmission angle of a four-bar mechanism. What are the maximum and minimum values of transmission angle? Sketch them.
3. What will be the rubbing velocity at pin joint when two links move in the same and opposite directions?
4. State and prove Kennedy's three centre theorem.
5. What is maximum velocity and acceleration of the follower on both the strokes of uniform acceleration and retardation.
6. Classify cams based on their physical shape.
7. Define the terms : Module and Pitch Circle diameter of a spur gear.
8. What is meant by interference and undercutting of gears?
9. Differentiate Self-energizing and self locking brakes.
10. What are the disadvantages of V-belt drive over flat belt?

PART B — (5 × 13 = 65 marks)

11. (a) Briefly explain the following inversions :
- (i) Beam engine
  - (ii) Scotch yoke mechanism
  - (iii) Crank and slotted lever quick return mechanism. (13)

Or

- (b) (i) Explain different types of constrained motion with suitable examples. (6)
- (ii) Describe the working of Peaucellier mechanism and Offset slider mechanism. (7)
12. (a) A mechanism, as shown in Fig.12(a), has the following dimensions : OA = 200 mm; AB = 1.5 m; BC = 600 mm; CD = 500 mm and BE = 400 mm. Locate all the instantaneous centres. If crank OA rotates uniformly at 120 r.p.m clockwise, find
- (i) the velocity of D and
  - (ii) the angular velocity of the links AB and CD. (13)

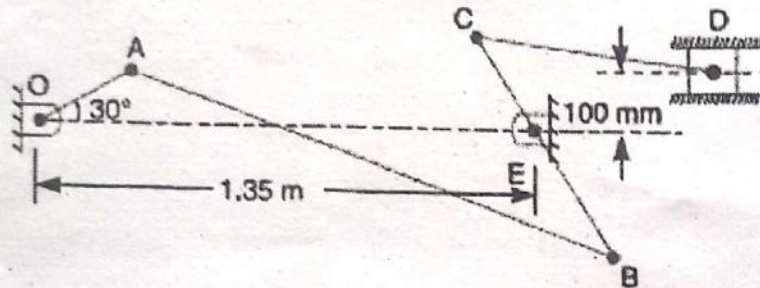

Figure 12(a)

Or

- (b) In a mechanism as shown in Fig. 12(b), the various dimensions are : OC = 125 mm; CP = 500 mm; PA = 125 mm; AQ = 250 mm and QE = 125 mm. The slider P translates along an axis which is 25 mm vertically below point O. The crank OC rotates uniformly at 120 r.p.m. in the anti-clockwise direction. The bell crank lever AQE rocks about fixed centre Q. Draw the velocity diagram and calculate the absolute velocity of point E of the lever. (13)

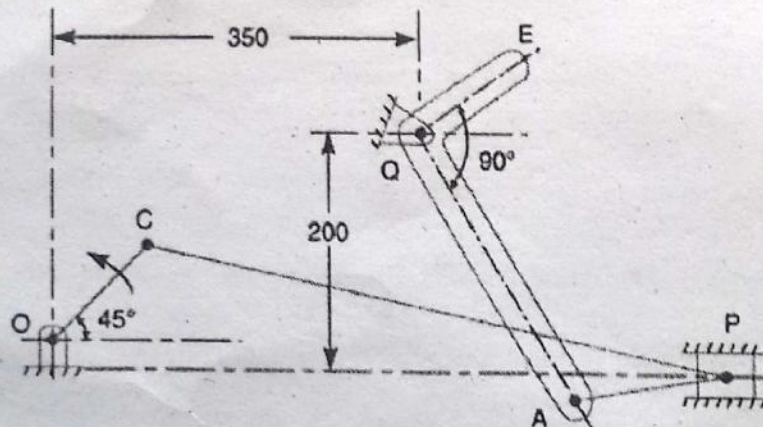

Figure 12(b)

13. (a) Draw a cam profile to drive an oscillating roller follower to the specifications given below :
- Follower to move outwards through an angular displacement of  $20^\circ$  during the first  $120^\circ$  rotation of the cam;
  - Follower to return to its initial position during next  $120^\circ$  rotation of the cam;
  - Follower to dwell during the next  $120^\circ$  of cam rotation. The distance between pivot centre and roller centre = 120 mm; distance between pivot centre and cam axis = 130 mm; minimum radius of cam = 40 mm; radius of roller = 10 mm; inward and outward strokes take place with simple harmonic motion. (13)

Or

- (b) The following particulars relate to a symmetrical circular cam operating a flat faced follower; least radius = 25 mm, nose radius = 8 mm, lift of the valve = 10 mm, Angle of action of cam =  $120^\circ$ , cam shaft speed = 1000 rpm. Determine the flank radius and maximum velocity, acceleration and retardation of the follower. Draw profile of the cam. (13)
14. (a) (i) Prove that the max. length of arc of contact between a pair of gear tooth to avoid interference is  $(r + R)\tan \phi$ . (5)
- (ii) Two mating gears have 20 and 40 involute teeth of module 10 mm and  $20^\circ$  pressure angle. The addendum on each wheel is to be made of such a length that the line of contact on each side of the pitch point has half the maximum possible length. Determine the addendum height for each gear wheel, length of the path of contact. (8)

Or

- (b) A compound epicyclic gear is shown in Fig. 14(b). The gears A, D and E are free to rotate on axis P. The compound gear B & C rotate together on the axis Q at the end of arm F. All gears have equal pitch. The number of external teeth on gears A, B and C are 18, 45 and 21 respectively. The gears D & E are annular gears. The gear A rotates at 100 rpm in anticlockwise direction and gear D rotates at 450 rpm clockwise. Find the speed and direction of the arm and the gear E. (13)

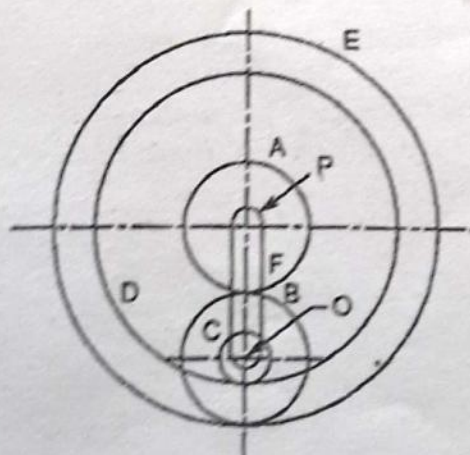

Figure 14(b)

15. (a) The mean diameter of the screw jack having pitch of 10 mm is 50 mm. A load of 20 kN is lifted through a distance of 170 mm. Find the work done in lifting the load and efficiency of the screw jack when (i). The load rotates with the screw and (ii) The load rests on the loose head which does not rotate with the screw. The external and internal diameters of the bearing surface of the loose head are 60mm and 10mm respectively. The coefficient of friction for the screw as well as the bearing surface may be taken as 0.08. (13)

Or

- (b) A leather faced conical clutch has a cone angle of  $30^\circ$ . If the intensity of pressure between the contact surfaces is limited to  $0.35 \text{ N/mm}^2$  and the breadth of the conical surface is not to exceed of one-third of the mean radius. Determine the dimensions of the contact surfaces to transmit 22.5 kW at 2000 rpm. Assume uniform wear rate and take coefficient of friction as 0.15. (13)

PART C — (1 × 15 = 15 marks)

16. (a) A compressor, requiring 90KW to operate at 250 rpm. The drive is by V-belts from an electric motor running at 750 rpm. The diameter of the pulley on the compressor shaft must not be greater than 1 meter while the center distance between the pulleys is limited to 1.75 m. The belt speed should not exceed 1600 m/min. Determine the number of V belts required to transmit the power if each belt has a cross sectional area of  $375 \text{ mm}^2$ , density  $1000 \text{ kg/m}^3$  and an allowable tensile stress of 2.5 Mpa. The groove angle of the pulley is  $35^\circ$ . The coefficient of friction between the belt and the pulley is 0.25. Also calculate the length of each belt. (15)

Or

- (b) (i) Derive an expression for minimum number of teeth on the wheel in order to avoid interference. (7)
- (ii) In a crank and slotted lever quick return motion mechanism, the distance between the fixed centers is 240mm and the length of the driving crank is 120 mm. Determine the inclination of the slotted bar with the vertical in the extreme position and the time ratio. If the length of the slotted bar is 450mm, find the length of the stroke if the line of stroke passes through the extreme positions of the free end of the lever. (8)