



Reg. No. :

--	--	--	--	--	--	--	--	--	--	--	--	--	--	--	--	--	--	--	--

Question Paper Code : 50872

B.E./B.Tech. DEGREE EXAMINATION, NOVEMBER/DECEMBER 2017
Fourth/Fifth/Sixth Semester
Mechanical Engineering
ME 6503 – DESIGN OF MACHINE ELEMENTS
(Common to Mechanical Engineering (Sandwich)/Automobile Engineering/
Industrial Engineering/Mechanical and Automation Engineering/Mechatronics
Engineering)
(Regulations 2013)

Time : Three Hours

Maximum : 100 Marks

Usage of PSG design data book is permitted.

Answer ALL questions..

PART – A

(10×2=20 Marks)

1. What is shock factor and what does it indicate ?
2. Differentiate hardness and toughness.
3. List the different types of sunk keys and draw any one.
4. Differentiate rigid and flexible couplings.
5. State the disadvantages of welded joints.
6. What is known as proof load in bolts ?
7. While designing helical springs, K is introduced in the shear stress equation, why ?
8. List the advantages of hydrostatic bearings.
9. Brief why fly wheels are used in punching machines.
10. What type of bearings can take axial load ?

PART – B

(5×13=65 Marks)

11. a) Design a journal bearing for a 49.9 mm dia journal. It is ground and hardened and is rotating at 1500 rpm in a bearing of diameter and length 50 mm. The inlet temperature of oil 65°C. Determine a) maximum radial load that the journal can carry b) power loss.

(OR)



- b) A deep groove ball bearing No. 6308 selected for a particular application, carries a radial load of 2900 N and a thrust load of 1800 N ; both being steady. The inner race of the bearing rotates at 900 r.p.m. The bearing is required to have a minimum life of 9000 hours. Check whether the bearing selected can serve the purpose.
12. a) A bolt is subjected to a direct load of 25 kN and shear load of 15 kN. Considering following theories of failure, determine a suitable size of the bolt if the material of the bolt is C15 having 200 N/mm^2 yield strength. Assume F.O.S. as 2 and also give your comments.
- Maximum normal stress theory
 - Maximum shear stress theory
 - Von misses theory.
- (OR)
- b) A mass of 50 kg drops through 25 mm at the centre of a 250 mm long simply supported beam. The beam has a square cross section. It is made of steel 30C8 ($S_{yt} = 400 \text{ N/mm}^2$) and the factor of safety is 2. The modulus of elasticity is 207000 N/mm^2 . Determine the dimension of the cross section of the beam.
13. a) A 600 mm diameter pulley driven by a horizontal belt transmits power through a solid shaft to a 262 mm diameter pinion which drives a matting gear. The pulley weighs 1200 N to provide some flywheel effect. The arrangement of elements, the belt tensions and components of the gear reactions on the pinion are as indicated in Figure 13(a). Determine the necessary shaft diameter using a suitable value for commercial shafting and shock fatigue factors of $K_b = 2$ and $K_t = 15$.

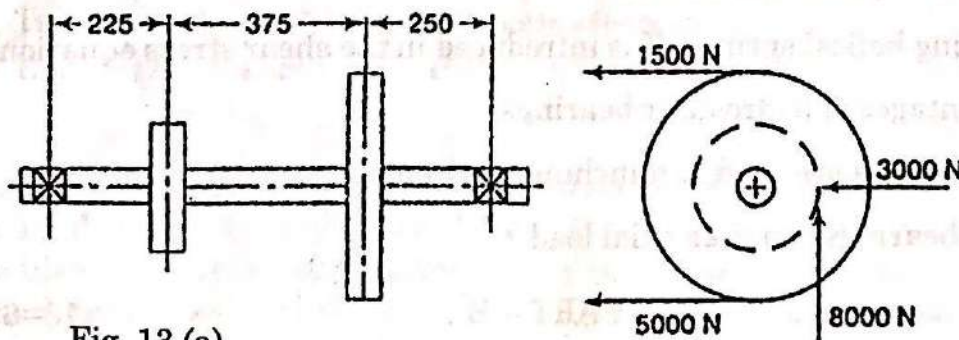

Fig. 13 (a)

(OR)



- b) A shaft made of AISI 1030 cold drawn steel ($\sigma_u = 520 \text{ MPa}$ and $\sigma_y = 440 \text{ MPa}$) transmits 50 kW at 900 rpm through a gear. Select an appropriate square key for the gear.
14. a) An ISA 200 × 100 × 100 angle is welded to a steel plate by means of fillet welds as shown in Fig 14 (a). The angle is subjected to a static force of 150 kN and permissible shear stress for the weld is 70 N/mm^2 . Determine the lengths of the weld at the top and bottom.

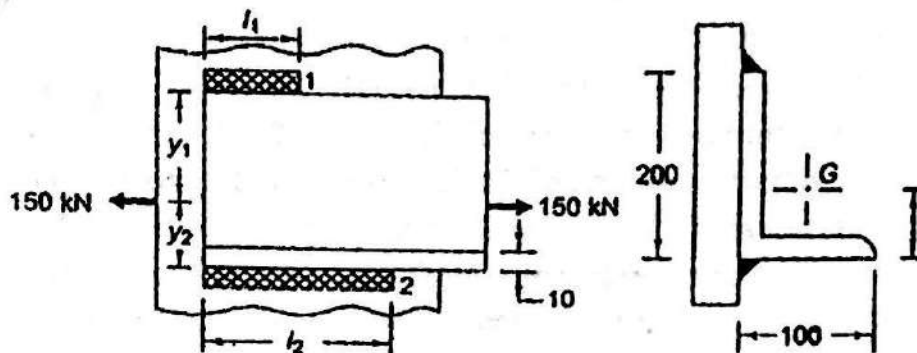

Fig. 14 (a)

(OR)

- b) Fig. 14(b) shows a bracket fixed on a steel column by means of 3 bolts of same size. If the permissible tensile and shear stress are limited to 75 N/mm^2 and 55 N/mm^2 respectively. Find the size of bolts.

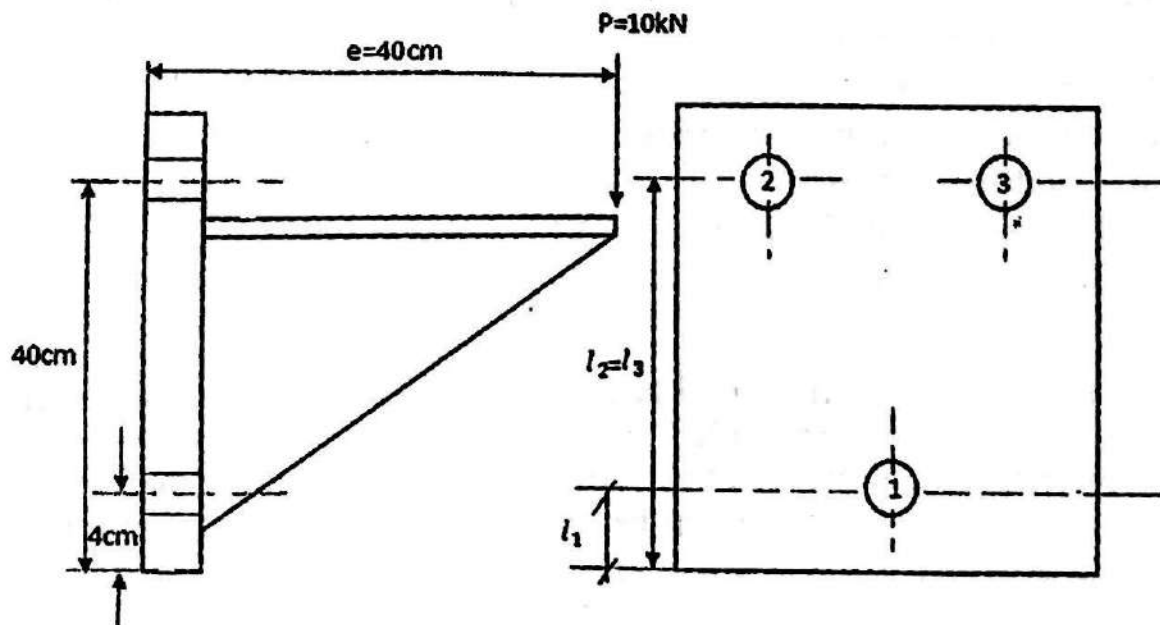

Fig. 14 (b)



15. a) A spring loaded safety valve for a boiler is required to blow off at a pressure of 0.8 MPa. The diameter of valve seat is 90 mm and maximum lift of valve is 10 mm. Design a suitable spring for the valve assuming the spring index as 7. Provide an initial compression of 30 mm. Take allowable shear stress as 420 MPa.

(OR)

- b) A punching machine makes 25 working strokes per minute and is capable of punching 25 mm diameter holes in 18 mm thick steel plates having an ultimate shear strength of 3000 kg/cm^2 . The punching operation takes place during $1/10^{\text{th}}$ of a revolution of the crank shaft. Estimate the horse power needed for the driving motor, assuming a mechanical efficiency of 95 %. Determine suitable dimensions for the rim cross section of the flywheel, which is to revolve at 9 times the speed of crankshaft. The permissible fluctuation of speed is 0.1. The flywheel is to be made of cast iron having a working stress (tensile) of 60 kg/cm^2 and weighing 7.25 gm/cu. cm . The diameter of the flywheel must not exceed 149 cm owing to space restrictions. The hub and spokes may be assumed to provide 5% of the rotational inertia of the wheel. Check for the centrifugal stress induced in the rim.

PART – C

(1×15=15 Marks)

16. a) A machine component is subjected to a flexural stress which fluctuates between $+ 300 \text{ MN/m}^2$ and -150 MN/m^2 . Determine the value of minimum ultimate strength according to
- 1) Gerber relation
 - 2) Modified Goodman relation and
 - 3) Soderberg relation.

Take yield strength = 0.55 Ultimate strength ;

Endurance strength = 0.5 Ultimate strength ; and factor of safety = 2.

(OR)

- b) It is required to design a knuckle joint to connect two circular rods subjected to an axial tensile force of 50 kN. The rods are co-axial and a small amount of angular movement between their axes is permissible. Design the joint and specify the dimensions of its components. Select suitable materials for the parts. Assume rod materials as 30C8 and FOS = 5.