



Department of Electronics and Communication Engineering

EC8453-Linear Integrated Circuits

Unit II - MCQ Bank

1. A voltage follower

- A) Has a voltage gain of 1
- B) Is non-inverting
- C) Has no feedback resistor
- D) Has all of these**

Answer: (D)

2. A Voltage to current converter is also called as

- a) Current series positive feedback amplifier
- b) Voltage series negative feedback amplifier
- c) Current series negative feedback amplifier**
- d) Voltage series positive feedback amplifier

Answer: (C)

3. Given voltage to current converter with floating load. Determine the output current?

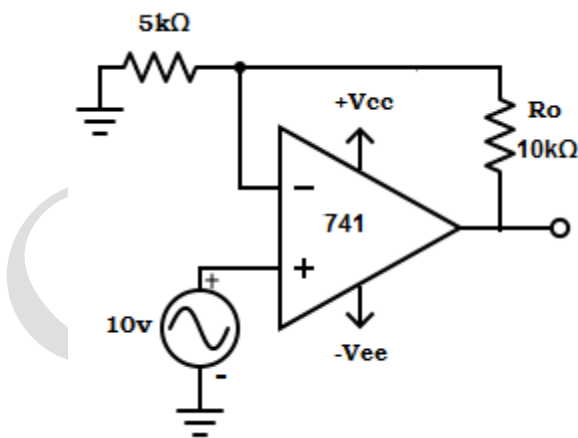

A) 3mA

- B) 6mA
- C) 4mA
- D) 2mA**

Answer: (D)

4. Which cell can be used instead of a photocell to obtain active transducer in photosensitive devices?

- A) Photovoltaic cell**
- B) Photo diode
- C) Photo sensor
- D) All of the mentioned

Answer: (A)

5. Determine the output voltage when $V_1 = -V_2 = 1$ V.

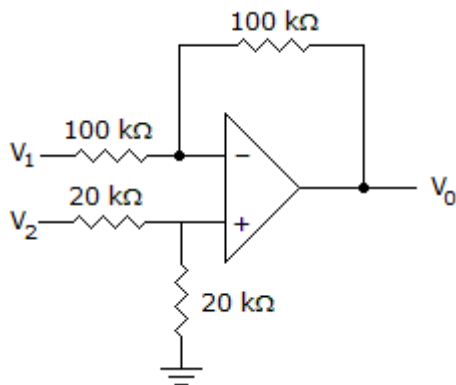

- A) 0 V
- B) -2 V**
- C) 1 V
- D) 2V

Answer: (B)

6. What are the features of instrumentation amplifier?

- A) Low noise
- B) High gain accuracy
- C) Low thermal and time drift

D) All of the mentioned

Answer: (D)

7. Find the output voltage of the integrator

A) $V_o = (1/R \times C_F) \times \int_0^t V_{in} dt + C$

B) $V_o = (R/C_F) \times \int_0^t V_{in} dt + C$

C) $V_o = (C_F/R) \times \int_0^t V_{in} dt + C$

D) $V_o = (R \times C_F) \times \int_0^t V_{in} dt + C$

Answer: (A)

8. How a perfect integration is achieved in op-amp?

A) **Infinite gain**

B) Low input impedance

C) Low output impedance

D) High CMRR

Answer: (A)

9. Which factor makes the differentiator circuit unstable?

A) Output impedance

B) Input voltage

C) Noise

D) **Gain**

Answer: (D)

10. Determine the transfer function for the practical differentiator

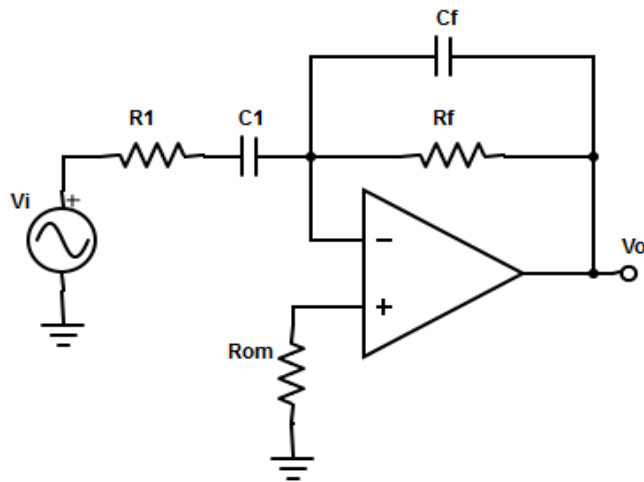

- A) $V_o(s) / V_i(s) = -S \times R_F \times C_1 / (1 + R_1 \times C_1)^2$
 B) $V_o(s) / V_i(s) = -S \times R_F \times C_1 / (1 + R_F \times C_1)^2$
 C) $V_o(s) / V_i(s) = -S \times R_F \times C_1 / (1 + R_1 \times C_F)^2$
 D) None of the mentioned

Answer: (A)

11. Find the circuit that is used to compress the dynamic range of a signal?

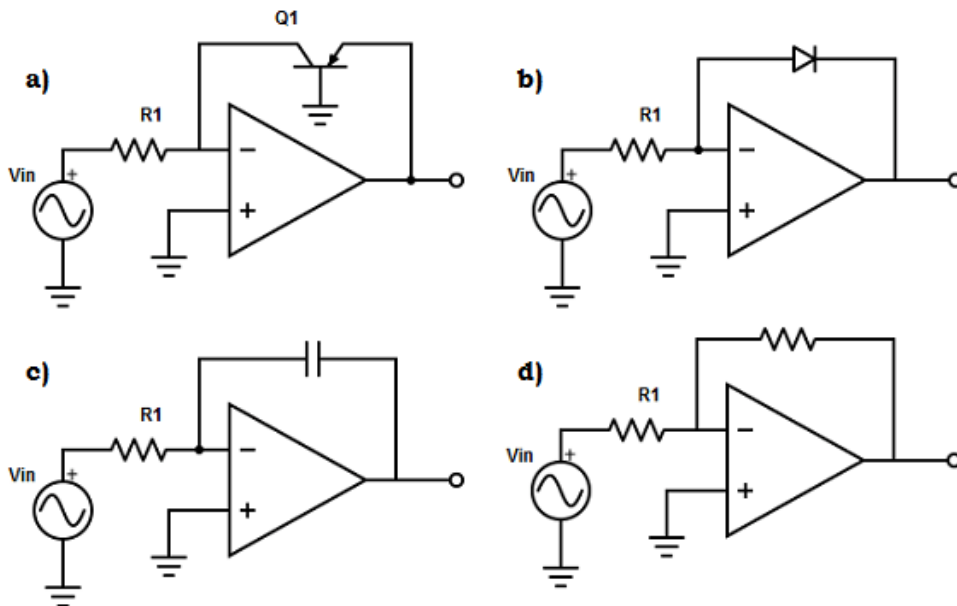

Answer: (A)

12. Find the output voltage of the log-amplifier

- a) $V_O = -(kT) \times \ln(V_i/V_{ref})$
- b) $V_O = -(kT/q) \times \ln(V_i/V_{ref})$
- c) $V_O = -(kT/q) \times \ln(V_{ref}/V_i)$
- d) $V_O = (kT/q) \times \ln(V_i/V_{ref})$

Answer: (B)

13. Find the non-inverting comparator

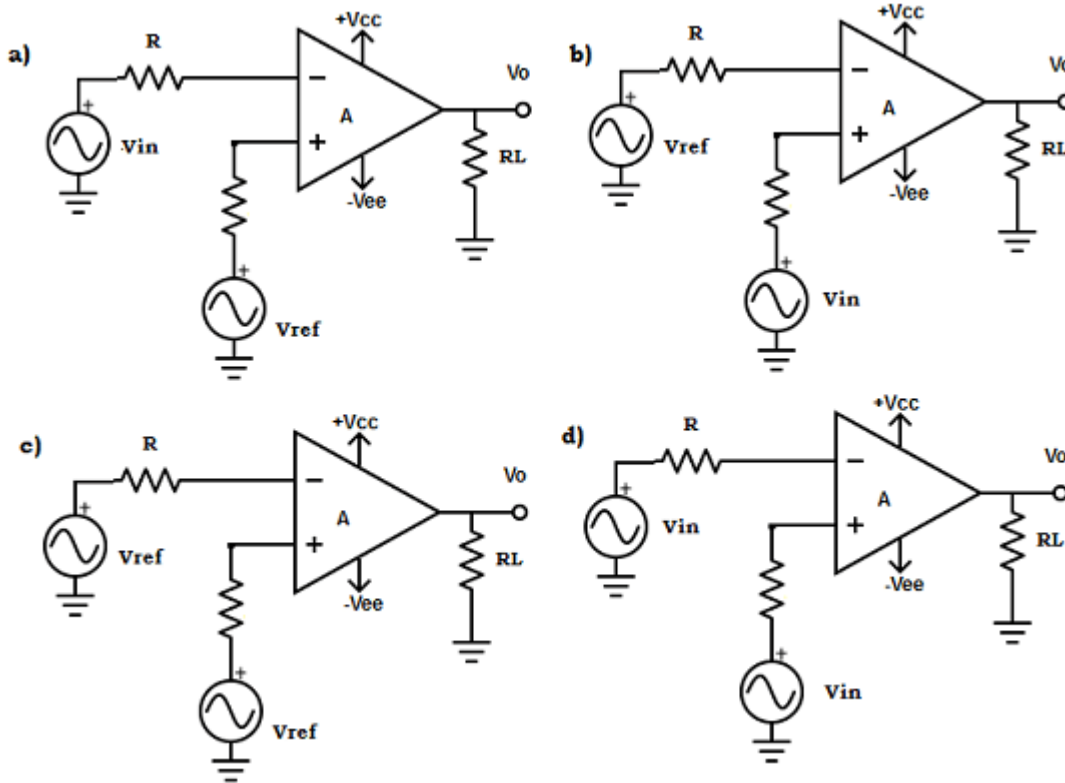

Answer: (A)

14. How to obtain high rate of accuracy in comparator?

- A) Input offset
- B) High voltage gain
- C) High CMRR
- D) All of the mentioned**

Answer: (D)

15. Zero crossing detectors is also called as

- A) Square to sine wave generator
- B) Sine to square wave generator**
- C) Sine to triangular wave generator
- D) All of the mentioned

Answer: (B)

16. Which circuit converts irregularly shaped waveform to regular shaped waveforms?

- A) Schmitt trigger**
- B) Voltage limiter
- C) Comparator
- D) None of the mentioned

Answer: (A)

17. In which configuration a dead band condition occurs in schmitt trigger

- A) Differential amplifier with positive feedback
- B) Voltage follower with positive feedback
- C) Comparator with positive feedback**
- D) None of the mentioned

Answer: (C)

18. The diode rectifier works well enough if the supply voltage is much than greater than 0.7V. For smaller voltage (of few hundreds of millivolt) input which of the following can be used?

- A) Superdiode**
- B) Peak rectifier
- C) Precision rectifier
- D) None of the mentioned

Answer: (A)

19. What is the alternate method to measure the values of non-sinusoidal waveform other than ac voltmeter?

- A) Clipper
- B) Clamper
- C) Peak detector**
- D) Comparator

Answer: (C)

20. The resistor in the peak detector are used to

- A) To maintain proper operation
- B) Protect op-amp from damage**
- C) To get shaped non-sinusoidal waveform
- D) None of the mentioned

Answer: (B)

21. Which circuit is used for obtaining desired output waveform in operational amplifier?

- A) Clipper**
- B) Clamper
- C) Peak amplifier
- D) Sample and hold

Answer: (A)

22. In a positive clipper, the diode conducts when

- A) $V_{in} < V_{ref}$
- B) $V_{in} = V_{ref}$**
- C) $V_{in} > V_{ref}$
- D) None of the mentioned

Answer: (B)

23. Find the output waveform for when $V_{in} < V_{ref}$

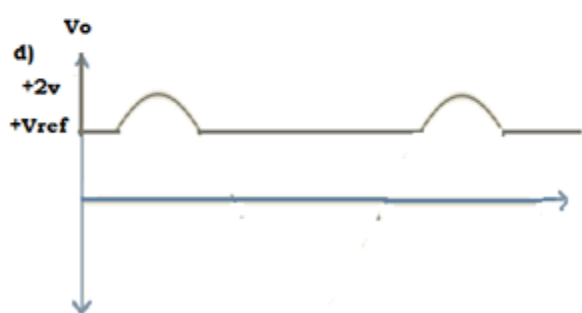
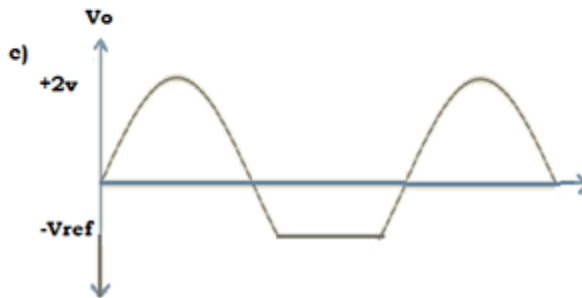
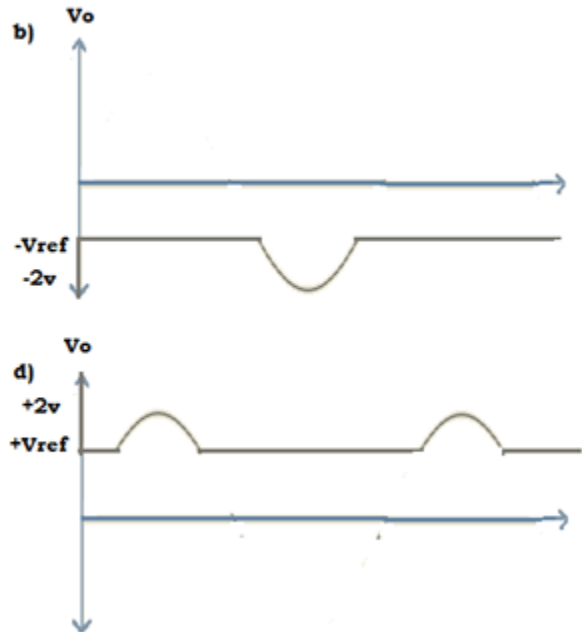
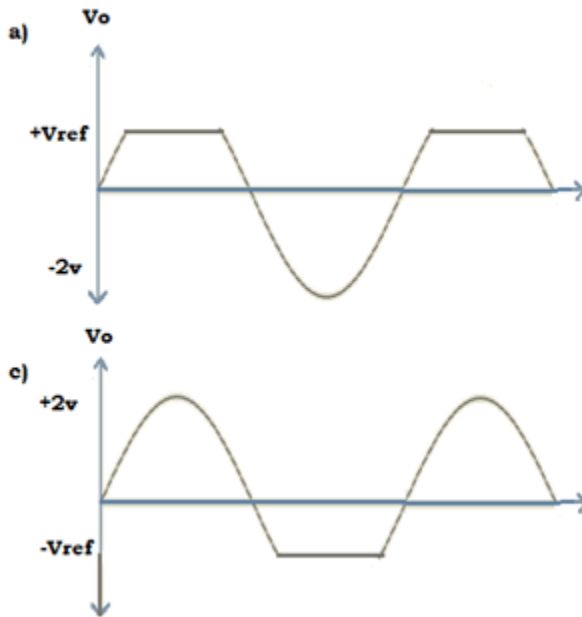
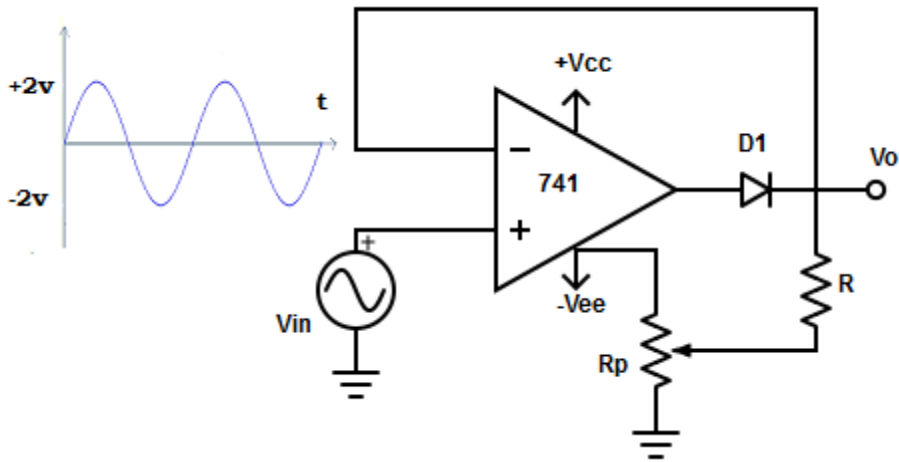

Answer: (C)

24. Find the voltage across the capacitor in the given circuit

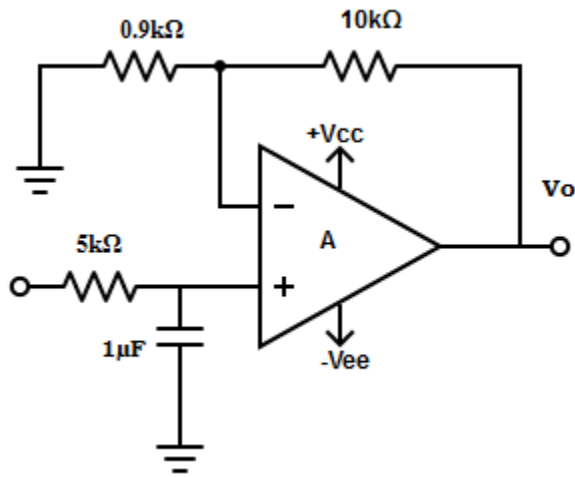

- A) $V_O = V_{in} / (1 + 0.0314jf)$
- B) $V_O = V_{in} \times (1 + 0.0314jf)$
- C) $V_O = V_{in} + 0.0314jf / (1 + jf)$
- D) None of the mentioned

Answer: (A)

25. In a first order high pass filter, frequencies higher than low cut-off frequencies are called

- A) Stop band frequency
- B) Pass band frequency
- C) Centre band frequency
- D) None of the mentioned**

Answer: (D)